

Double-Data-Rate OPI Xccela PSRAM

Specifications

- **Single Supply Voltage**
 - VDD = 2.7 to 3.6V
 - VDDQ = 2.7 to 3.6V
- **Interface:** Octal Peripheral interface (OPI) with Xccela mode, two bytes transfers per one clock cycle
- **Performance:** Clock rate up to 133MHz, 266MB/s read/write throughput
- **Organization:** 64Mb, 8M x 8bits with 1024 bytes page size
 - Column address: AY0 to AY9
 - Row address: AX0 to AX12
- **Refresh:** Self-managed
- **Operating Temperature Range**
 - T_{OPER} = -40°C to +85°C (standard range)
 - T_{OPER} = -40°C to +105°C (extended range)
- **Maximum Standby Current**
 - 350µA @ 105°C
 - 250µA @ 85°C
- **Typical Standby Current**
 - 100µA @ 85°C

Features

- **Low Power Features**
 - Partial Array Self-Refresh (PASR)
 - Auto Temperature Compensated Self-Refresh (ATCSR) by built-in temperature sensor
 - User configurable refresh rate
- **Software Reset**
- **Reset Pin Available**
- **Output Driver LVCMOS** with programmable drive strength
- **Data Mask (DM)** for write data
- **Data Strobe (DQS)** enabled highspeed read operation
- **Register Configurable** write and read initial latencies
- **Write Burst Length**, maximum 1024 Byte, minimum 2 Byte.
- Wrap & Hybrid Burst in 16/32/64/1K lengths.
- **Linear Burst Command**
- **Row Boundary Crossing (RBX)**
 - read operations can be enabled via Mode Register
 - RBX Write is NOT supported.

Table of Contents

1 Table of Contents

1	Table of Contents.....	2
2	Package Information.....	3
3	Package Outline Drawing.....	4
4	Ordering Information.....	5
5	Signal Table	6
6	Block diagram.....	7
7	Power-Up Initialization	8
7.1	Power-Up Initialization Method 1 (via. RESET# pin).....	8
7.2	Power-Up Initialization Method 2 (via. Global Reset)	9
8	Interface Description	10
8.1	Address Space	10
8.2	Burst Type & Length.....	10
8.3	Command/Address Latching.....	10
8.4	Command Truth Table	10
8.5	Read Operation.....	11
8.6	Write Operation.....	14
8.7	Control Registers.....	15
9	Electrical Specifications:	21
9.1	Absolute Maximum Ratings.....	21
9.2	Pin Capacitance.....	21
9.3	Decoupling Capacitor Requirement.....	22
9.4	Operating Conditions.....	22
9.5	DC Characteristics	23
9.6	ISB Partial Array Refresh Current.....	24
9.7	AC Characteristics	25
10	Change Log.....	27

2 Package Information

The APS6408L-3OBMx is available in mini-BGA 24B package 6 x 8 x 1.2mm, ball pitch 1.0mm, ball size 0.4mm, package code "BA".

- Ball Assignment for MINI-BGA 24B

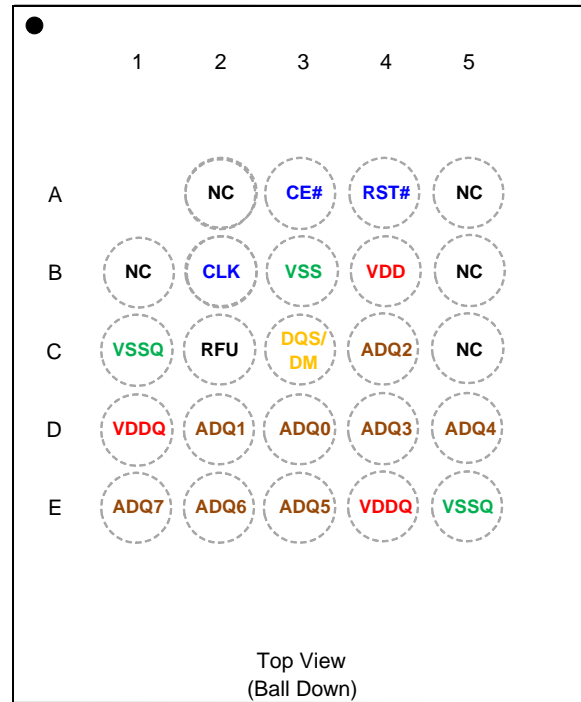

(6x8x1.2mm)(P1.0)(B0.4)

Note:

1. Part Number APS6408L-3OBM-BA for 64Mb.
2. RFU: Reserved for future use, which is reserved for 2nd CE#.
3. NC: No internal connection.

3 Package Outline Drawing

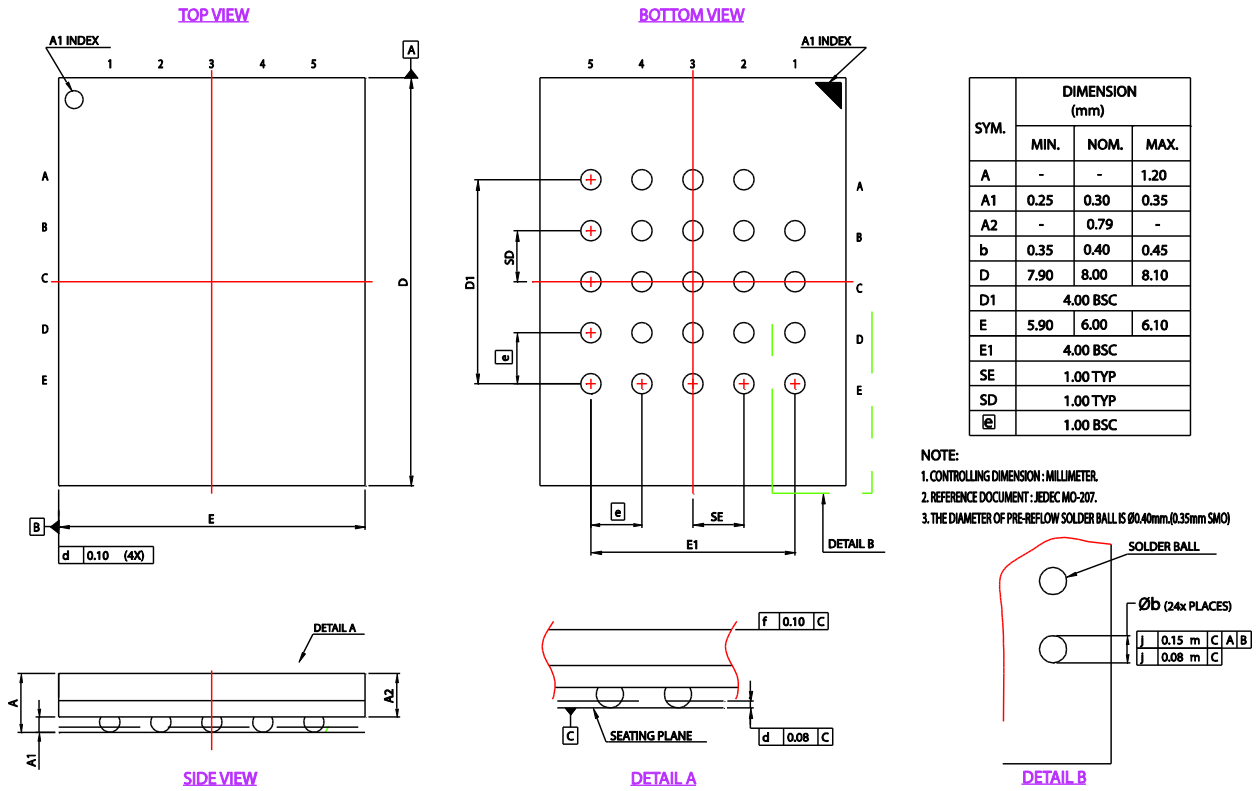

4 Ordering Information

Table 1: Ordering Information

Part Number	Temperature Range	Max Frequency	Note
APS6408L-3OBM	Tj= -40°C to +85°C	133 MHz	Bare die, SIP
APS6408L-3OBMX	Tj= -40°C to +105°C	133 MHz	Bare die, SIP
APS6408L-3OBM-BA	Tc= -40°C to +85°C	133 MHz	BGA 24B
APS6408L-3OBMX-BA	Tc= -40°C to +105°C	133 MHz	BGA 24B

Note

- 3OBM is standard part to support RBX read operation only.

IOT_SOPI_PN rule

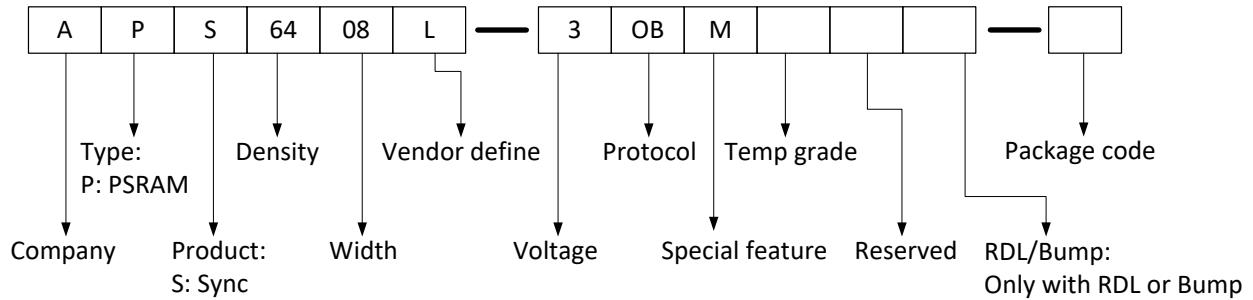

5 Signal Table

All signals are listed in Table 2.

Table 2: Signals Table

<i>Symbol</i>	<i>Type</i>	<i>Description</i>	<i>Comments</i>
V _{DD}	Power	Core supply 3.0V	
V _{DDQ}	Power	IO supply 3.0V	
V _{SS}	Ground	Core supply ground	
V _{SSQ}	Ground	IO supply ground	
A/DQ[7:0]	IO	Address/DQ bus [7:0]	
DQS/DM	IO	DQ strobe clock during reads, Data mask during writes. DM is active high. DM=1 means "do not write".	
CE#	Input	Chip select, active low. When CE#=1, chip is in standby state.	
CLK	Input	Clock signal	
RESET#	Input	Reset signal, active low. Optional, as the pad is internally tied to a weak pull-up and can be left floating.	

6 Block diagram

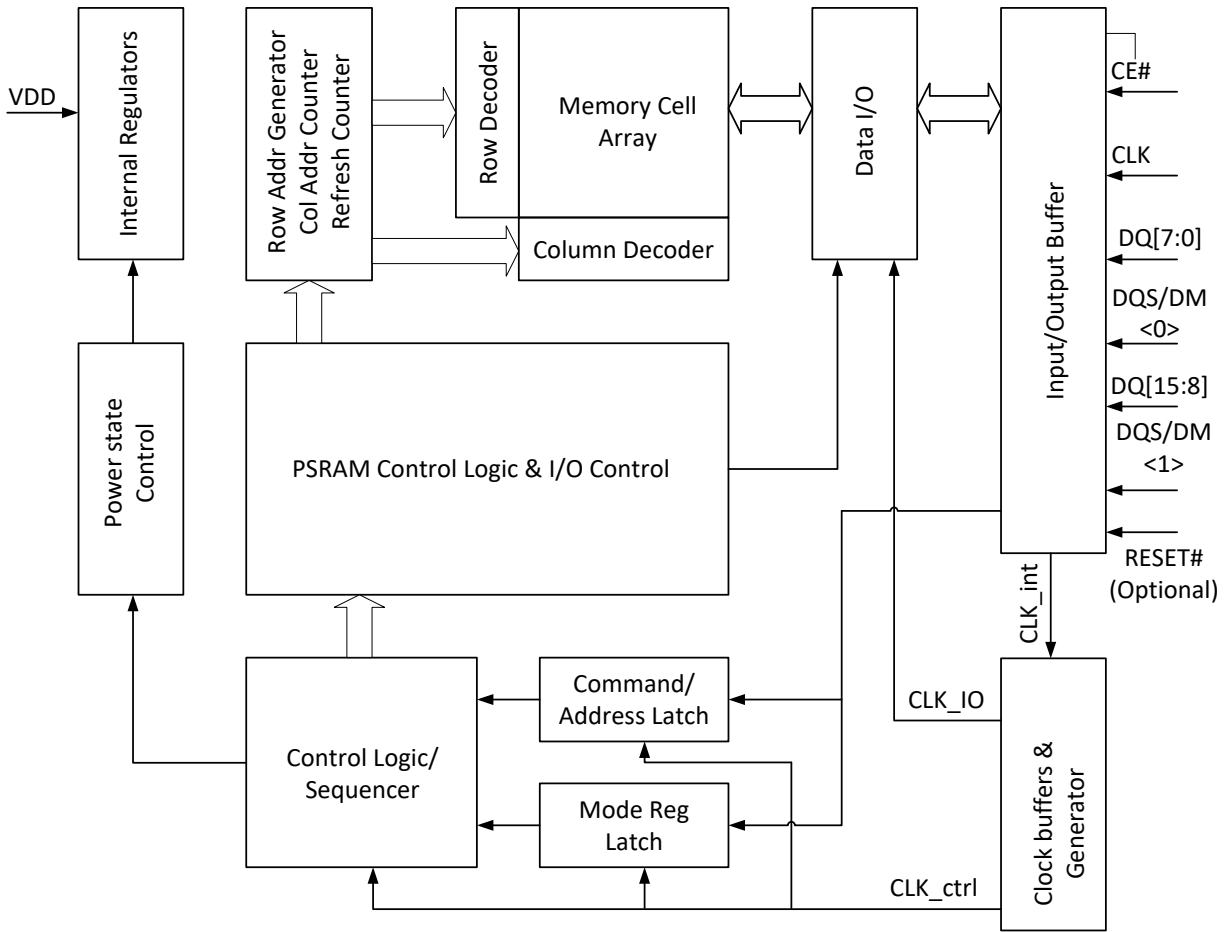

7 Power-Up Initialization

Octal DDR products include an on-chip voltage sensor used to start the self-initialization process. V_{DD} and V_{DDQ} must be applied simultaneously. When they reach a stable level at or above minimum V_{DD} , the device is in Phase 1 and will require $150\mu\text{s}$ to complete its self-initialization process. The user can then proceed to Phase 2 of the initialization described in this section.

During Phase 1 CE# should remain HIGH (track V_{DD} within 200mV); CLK should remain LOW.

After Phase 2 is complete the device is ready for operation.

7.1 Power-Up Initialization Method 1 (via. RESET# pin)

The RESET# pin can be used to initialize the device during Phase 2 as follows:

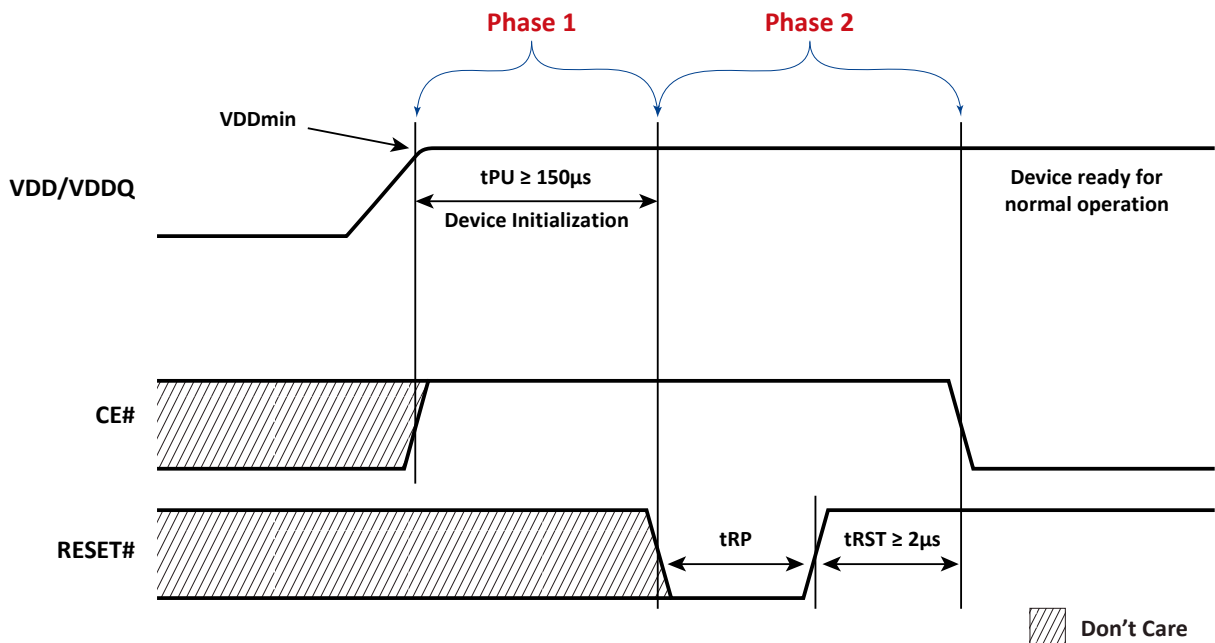

Figure 1. Power-Up Initialization Method 1 RESET#

The RESET# pin can also be used when CE#=high at any time after the device is initialized to reset all register contents. Memory content is not guaranteed. Timing requirements for RESET# usage are shown below.

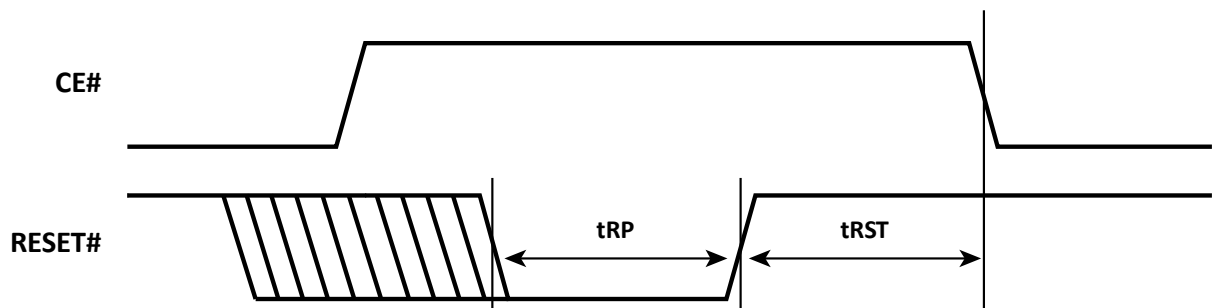

Figure 2. RESET# Timing

7.2 Power-Up Initialization Method 2 (via. Global Reset)

As an alternate power-up initialization method, After the Phase 1 150µs period the Global Reset command is used to reset the device in Phase 2 as follows:

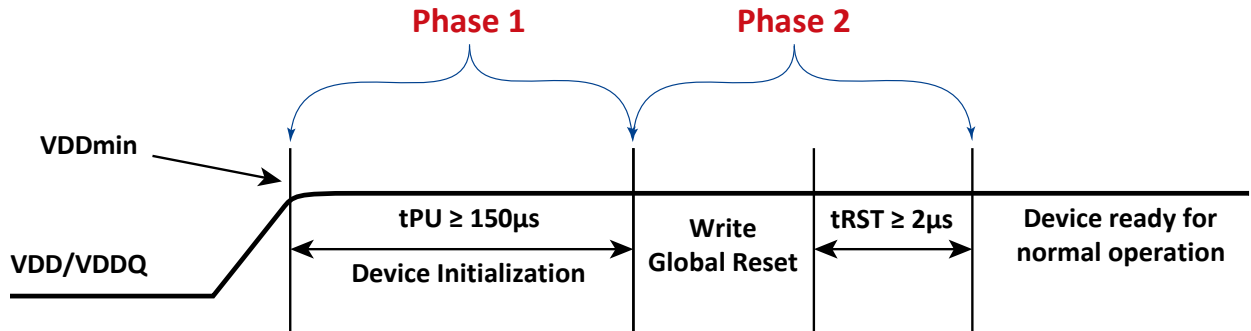

Figure 3. Power-Up Initialization Method 2 Timing with Global Reset

The Global Reset command resets all register contents. Memory content is not guaranteed. The command frame is made of 4 clocked CE# lows. Cloning is optional during tRST. The Global Reset command sequence is shown below. Note that Global Reset command can be used ONLY as Power-up initialization.

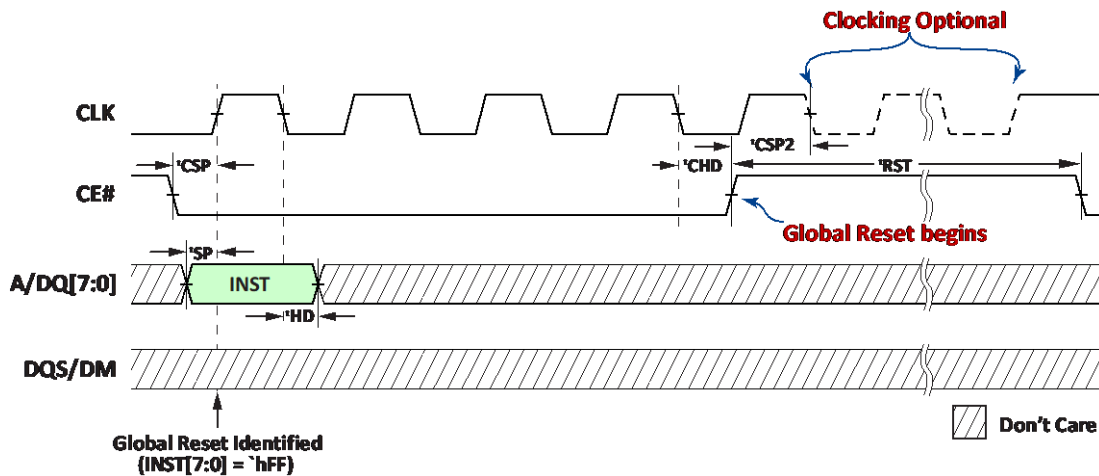

Figure 4: Global Reset

8 Interface Description

8.1 Address Space

Octal DDR PSRAM device is byte-addressable. Memory accesses are required to start on even addresses (A[0]=0). Mode Register accesses allow both even and odd addresses.

8.2 Burst Type & Length







Read and write operations are default Hybrid Wrap 32 mode. Other burst lengths of 16, 32, 64 or 1K bytes in standard or Hybrid wrap modes are register configurable (see Table 18) The device also includes command for Linear Bursting. Bursts can start on any even address. Write burst length has a minimum of 2 bytes. Read has no minimum length. Both write and read have no restriction on maximum burst length as long as tCEM is met.

8.3 Command/Address Latching

After CE# goes LOW, instruction code is latched on 1st CLK rising edge. Access address is latched on the 3rd, 4th, 5th & 6th CLK edges (2nd CLK rising edge, 2nd CLK falling edge, 3rd CLK rising edge, 3rd CLK falling edge).

8.4 Command Truth Table

The Octal DDR PSRAM recognizes the following commands specified on the INST (Instruction) cycle defined by the Address/DQ pins.

Command	1st CLK		2nd CLK		3rd CLK	
						
Sync Read	00h		A3	A2	A1	A0
Sync Write	80h		A3	A2	A1	A0
Sync Read (Linear Burst)	20h		A3	A2	A1	A0
Sync Write (Linear Burst)	A0h		A3	A2	A1	A0
Mode Register Read	40h		x			MA
Mode Register Write	C0h		x			MA
Global Reset	FFh		x			

Remarks: x = don't care (V_{IH}/V_{IL})

A3 = unused address bits are reserved

A2 = 1'bx, RA[12:6], unused address bit is reserved

A1 = RA[5:0], CA[9:8]

A0 = CA[7:0]

MA = Mode Register Address

8.5 Read Operation

After address latching, the device initializes DQS/DM to '0 from **next** CLK rising edge of the 3rd clock cycle (A1). See Figure 5 below.

Output data is available after LC latency cycles, as shown in Figure 7 & Figure 8, LC is defined in Table 5 and Table 6. When data is valid, A/DQ[7:0] and DQS/DM follow the timing specified in Figure 9. Synchronous timing parameters are shown in Table 28 & Table 29. CE# should be kept low until the last byte of data has been received by the host.

In case of internal refresh insertion, variable latency output data may be delayed by up to (LC*2) latency cycles as shown in Figure 7. True variable refresh pushout latency can be anywhere **between** LC to LCx2. The 1st DQS/DM rising edge after read pre-amble indicates the beginning of valid data.

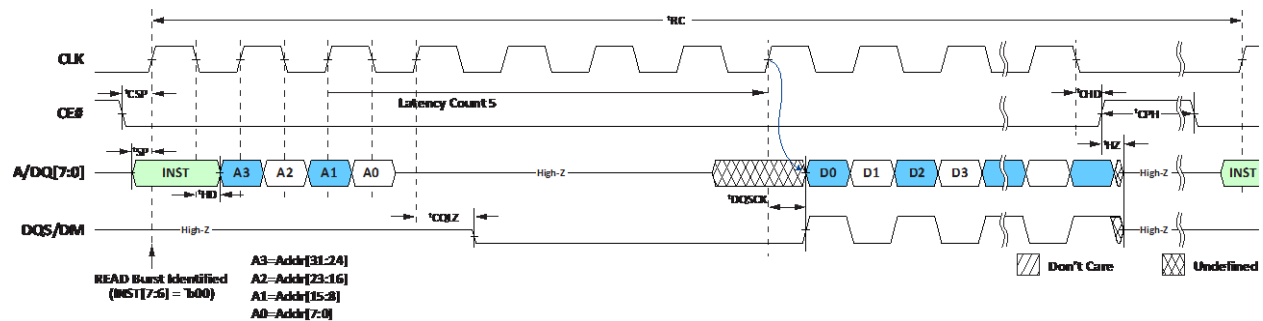

Figure 5: Synchronous Read

If RBX has been enabled (MR8[3] written to 1) and a Linear Burst Command issued, then Wrap settings (MR8[2:0]) are ignored and Read operations are allowed to cross row boundaries as shown in Figure 6.

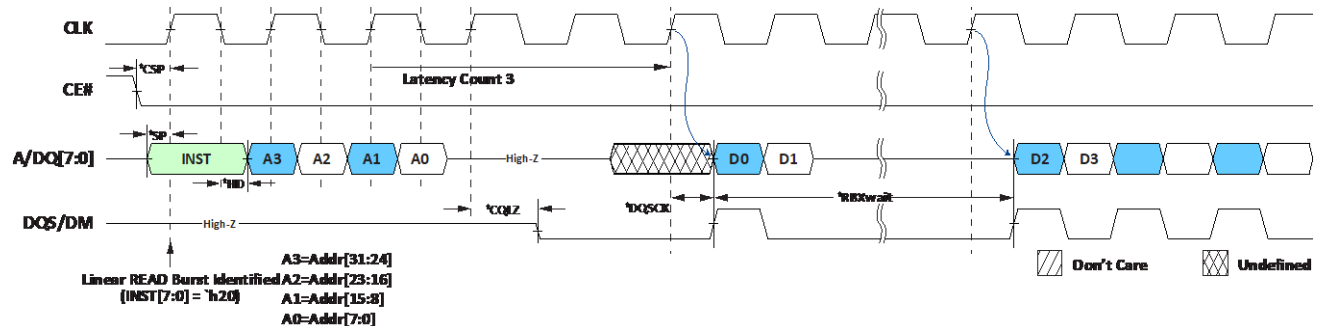

Figure 6: Synchronous Read with RBX (Starting address '3FE)

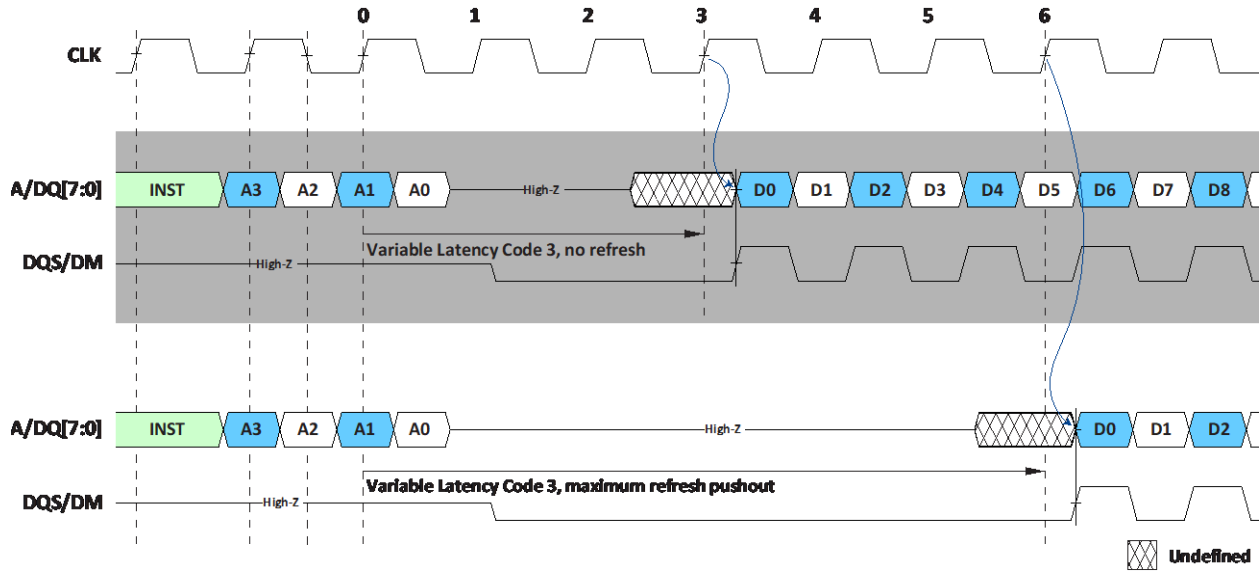

Figure 7: Variable Read Latency Refresh Pushout

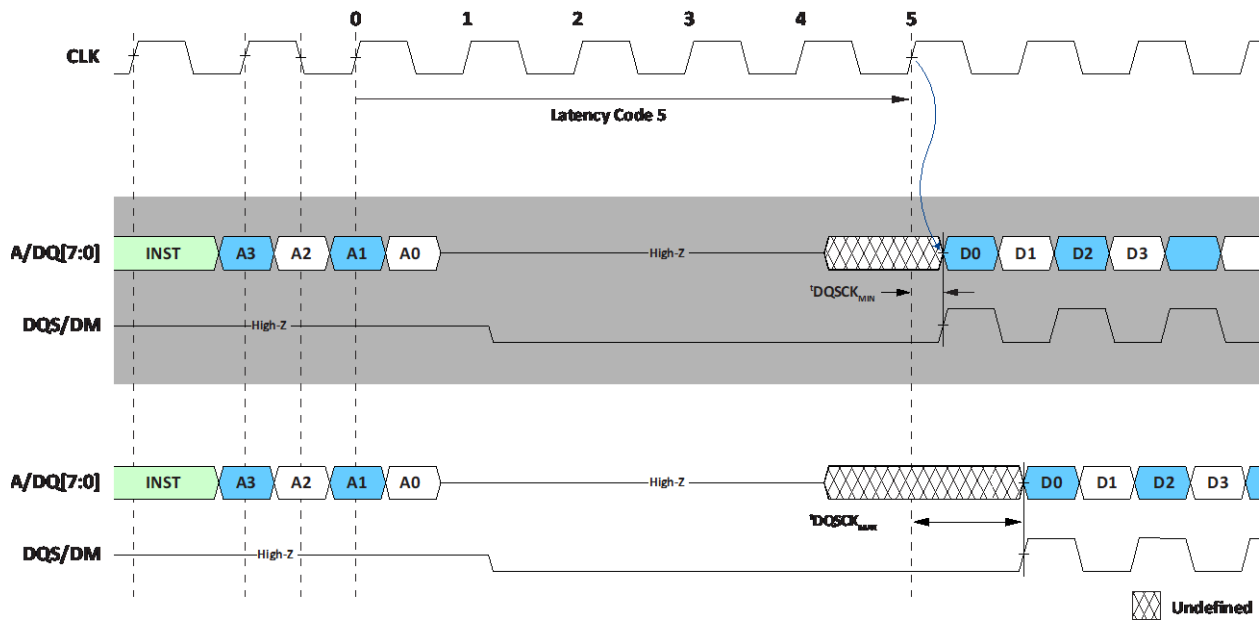

Figure 8: Read Latency & tDQSK

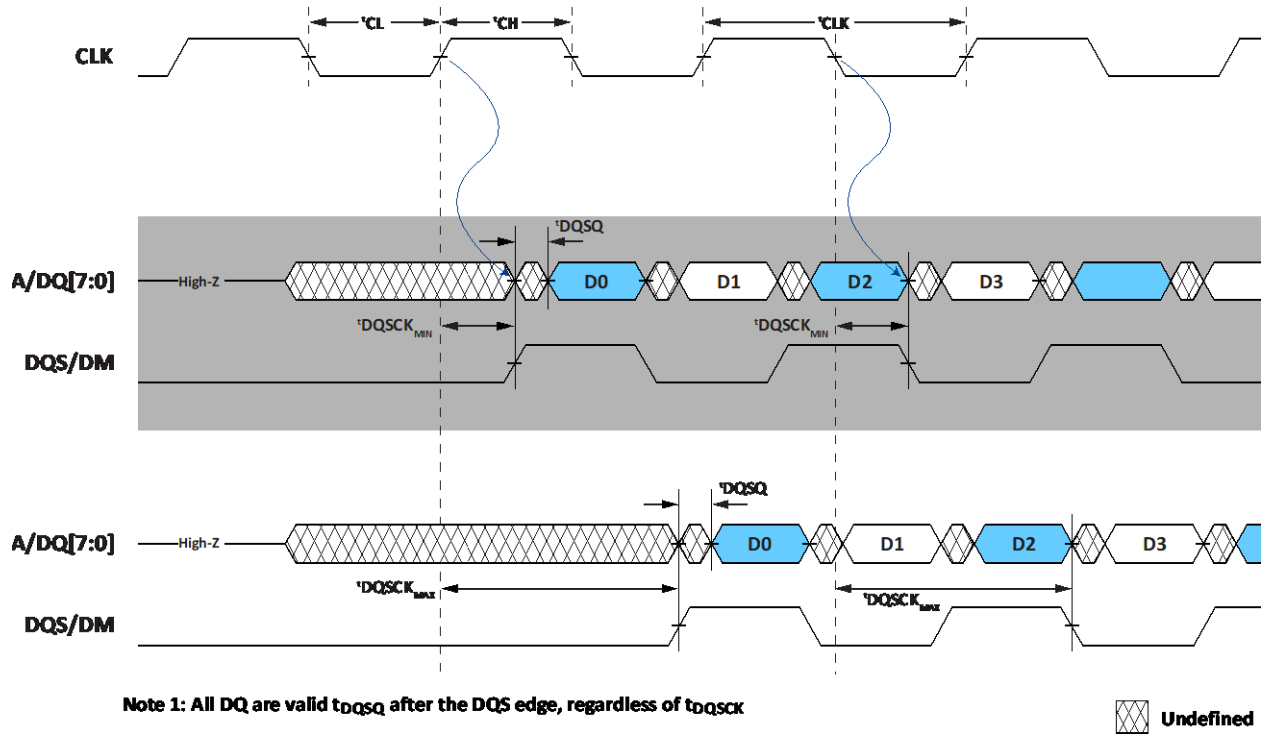

Figure 9: Read DQS/DM & DQ timing

8.6 Write Operation

A minimum of 2 bytes of data must be input in a write operation. In the case of consecutive short burst writes, t_{RC} must be met by issuing additional $CE\#$ high time between operations. Single-byte write operations can be performed by masking the un-written byte with DQS/DM as shown in Figure 10.

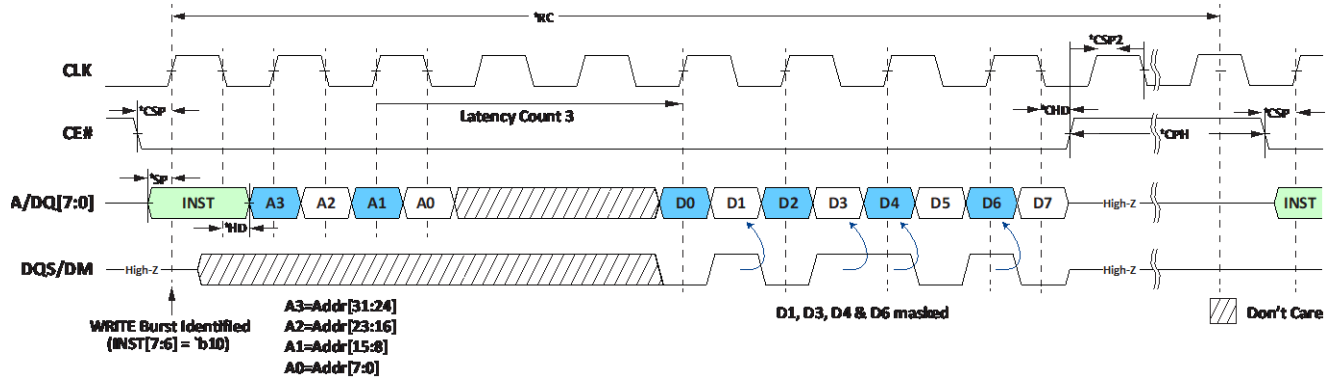

Figure 10: Synchronous Write followed by any Operation

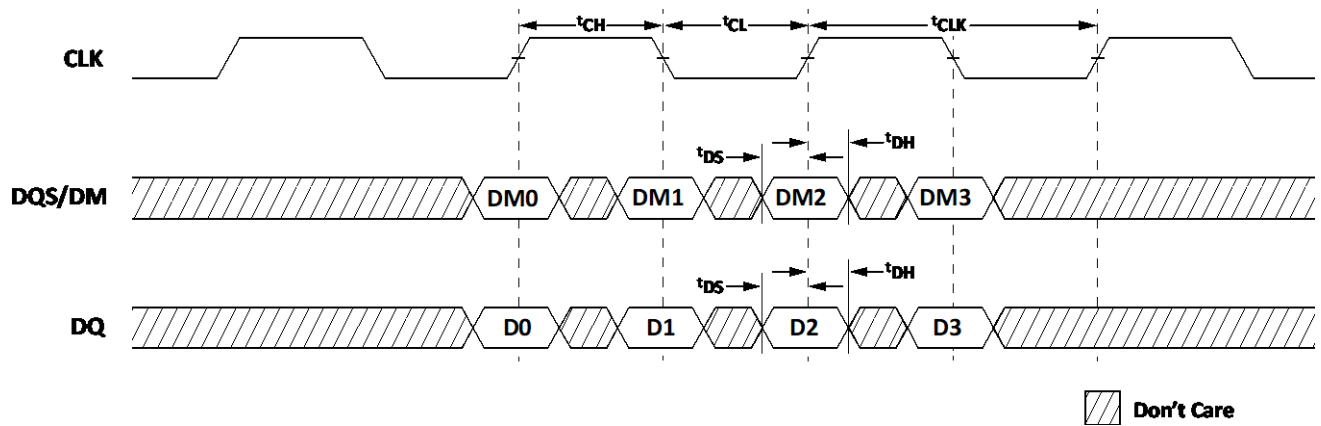

Figure 11: Write DQS/DM & DQ Timing

8.7 Control Registers

Register Read is shown below. Mode Address in command determines which Mode Register is read from as Data0 (see chart in the Figure below).

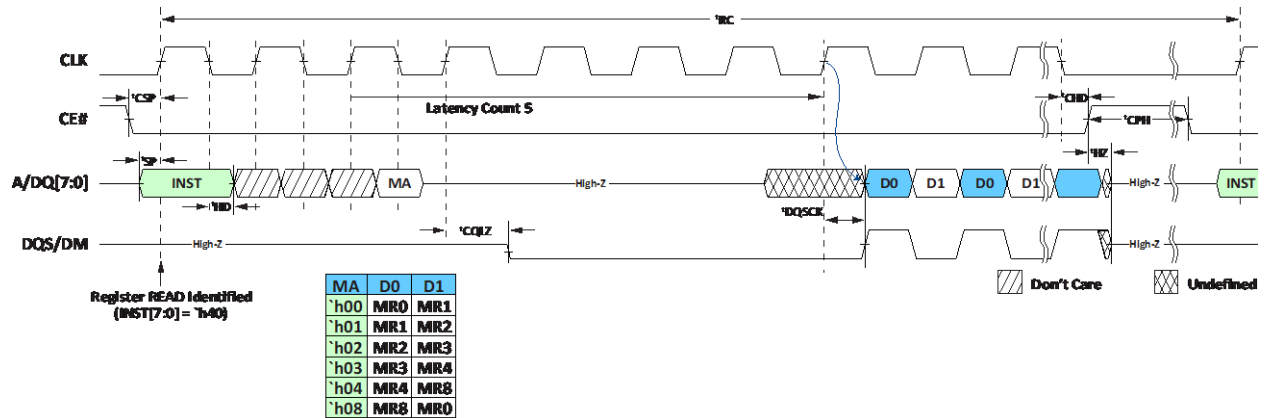

Figure 12: Register Read

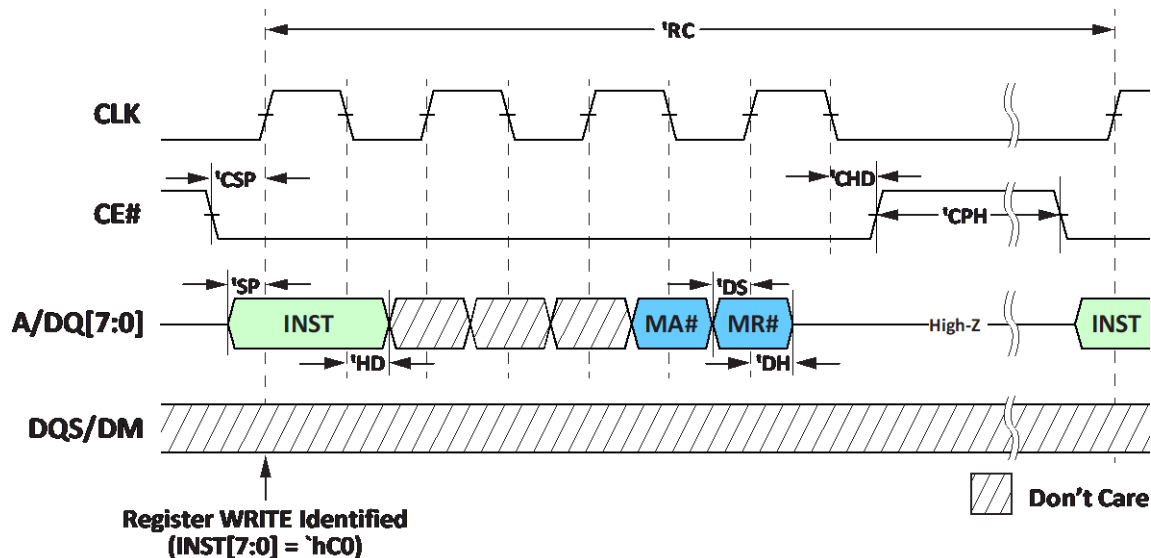

Figure 13: Register Write

Register Writes are Latency 1, whereas Register Reads use the same MR0[4:2] settings as burst reads (see Table 5). Registers 0, 4 & 8 are read and writable, and Registers 1, 2 and 3 are read-only. Register mapping is shown in Table 3. Note that MR0[6], MR0[7], MR4[4] and MR8[7] must be written to b'0.

Table 3: Mode Register Table

MR No.	MA[7:0]	Access	OP7	OP6	OP5	OP4	OP3	OP2	OP1	OP0	
0	`h00	R/W	'00'		LT	Read Latency Code			Drive Str.		
1	`h01	R	rsvd.			Vendor ID					
2	`h02	R	GB	rsvd.		Dev ID		Density			
3	`h03	R	RBXen	VCC	SRF	rsvd.					
4	`h04	R/W	Write Latency Code			'0'	RF	PASR			
8	`h08	R/W	'0'	rsvd.			RBX	BT	BL		

Table 4: Read Latency Type (MR0[5])

Latency Type	
MR0[5]	LT
0	Variable (default)
1	Fixed

Table 5: Read Latency Codes MR0[5:2]

MR0[4:2]	VL Codes (MR0[5]=0)		FL Codes (MR0[5]=1)	Max Input CLK Freq (MHz)	
	Latency (LC)	Max push out (LCx2)	Latency (LCx2)	Standard	Extended
000	3	6	6	66	66
001	4	8	8	109	109
010	5 (default)	10	10	133	133
others	reserved			-	-

Table 6: Operation Latency Code Table

Type	Operation	VL (default)		FL
		No Refresh	Refresh	
Memory	Read	LC	Up to LCx2	LCx2
	Write	WLC		WLC
Register	Read	LC		LC
	Write	1		1

*Note: see Table 15 for WLC settings.

Table 7: Drive Strength Codes MR0[1:0]

Codes	Drive Strength
'00	Half (50Ω)
'01	1/4 (100Ω default)
'10	1/8 (200Ω)
'11	1/16 (400Ω)

Table 8: Vendor ID mapping MR1[4:0]

Vendor ID
01101: APM

Table 9: Good-Die Bit MR2[7]*

Codes	Good Die ID
'1	PASS
'0	FAIL

*Note: Default is FAIL die, and only mark PASS after all tests passed.

Table 10: Device ID MR2[4:3]

Codes	Device ID
'00	Generation 1
'01	Generation 2
'10	Generation 3 (default)
others	reserved

Table 11: Device Density mapping MR2[2:0]

MR2[2:0]	Density
'001	32Mb
'011	64Mb (default)
'101	128Mb
'111	256Mb
'110	512Mb
others	reserved

Table 12: Row Boundary Crossing Enable (MR3[7])

MR3[7] (read-only)	RBXen
0	RBX not supported
1	RBX supported via MR8[3]=1

Table 13: Operating Voltage Range (MR3[6])

MR3[6]	VCC
0	1.8V
1	3V (default)

Table 14: Self Refresh Flag (MR3[5])

MR3[5] (read-only)	Self Refresh Flag
0	Slow Refresh (allowed via MR4[3]=1, otherwise Fast Refresh)
1	Fast Refresh

MR3[5] is a refresh indicator that corresponds to device internal temperature. This bit will indicate 0 when the temperature is low enough to allow a slow frequency refresh rate.

Table 15: Write Latency MR4[7:5]

Default powered up behavior is WL 5

MR4[7:5]	Write Latency Codes (WLC)	Fmax (MHz)
000	3	66
100	4	109
010	5 (default)	133
others	reserved	-

Table 16: Refresh Frequency MR4[3]

MR4[3]	Refresh Frequency
0	Fast Refresh (default)
1	Enables Slow Refresh when temperature allows

Table 17: PASR MR4[2:0]

The PASR bits restrict refresh operation to a portion of the total memory array. This feature allows the device to reduce standby current by refreshing only that part of the memory array required by the host system. The refresh options are full array, one-half array, one-quarter array, one-eighth array, or none of the array. The mapping of these partitions can start at either the beginning or the end of the address map.

64Mb				
Codes	Refresh Coverage	Address Space	Size	Density
'000	Full array (default)	000000h-7FFFFFFh	8M x8	64Mb
'001	Bottom 1/2 array	000000h-3FFFFFFh	4M x8	32Mb
'010	Bottom 1/4 array	000000h-1FFFFFFh	2M x8	16Mb
'011	Bottom 1/8 array	000000h-0FFFFFFh	1M x8	8Mb
'100	None	0	0M	0Mb
'101	Top 1/2 array	400000h-7FFFFFFh	4M x8	32Mb
'110	Top 1/4 array	600000h-7FFFFFFh	2M x8	16Mb
'111	Top 1/8 array	700000h-7FFFFFFh	1M x8	8Mb

Table 18: Burst Type MR8[2], Burst Length MR8[1:0]

By default the device powers up in 32 Byte Hybrid Wrap. In non-Hybrid burst (MR8[2]=0), MR8[1:0] sets the burst address space in which the device will continually wrap within. If Hybrid burst wrap is selected (MR8[2]=1), the device will burst through the initial wrapped burst length once, then continue to burst incrementally up to maximum column address (1K) before wrapping around within the entire column address space. Burst length (MR8[1:0]) can be set to 16,32,64 & 1K lengths.

MR8[2]	MR8[1:0]	Burst Length	Example of Sequence of Bytes During Wrap	
			Starting Address	Byte Sequence
'0	'00	16 Byte Wrap	4	[4,5,6,...15,0,1,2,...]
'0	'01	32 Byte Wrap	4	[4,5,6,...31,0,1,2,...]
'0	'10	64 Byte Wrap	4	[4,5,6,...63,0,1,2,...]
'0	'11	1K Byte Wrap	4	[4,5,6,...1023,0,1,2,...]
'1	'00	16 Byte Hybrid Wrap	2	[2,3,4,...15,0,1],16,17,18,...1023,0,1,...
'1	'01	32 Byte Hybrid Wrap (default)	2	[2,3,4,...31,0,1],32,33,34,...1023,0,1,...
'1	'10	64 Byte Hybrid Wrap	2	[2,3,4,...63,0,1],64,65,66,...1023,0,1,...
'1	'11	1K Byte Wrap	2	[2,3,4,...1023,0,1,2,...]

The Linear Burst Commands (INST[5:0]=6'b100000) override MR8[2:0] settings and forces the current array read or write command to do 1K Byte Wrap (equivalent to having MR8[1:0] set to 2'b11). The burst continues linearly from the starting address and at the end of the page, then wraps back to the beginning of the page. This special burst instruction can be used on both array write and read.

Table 19: Row Boundary Crossing Read Enable MR8[3]

This register setting applies to Linear Burst reads only on RBX enabled devices (MR3[7]=1). Default write and read burst behavior is limited within the 1K (CA='h000 -> 'h3FF) column address space. Setting this bit high will allow Linear Burst reads to cross over into the next Row (RA+1).

MR8[3]	RBX Read
0	Reads stay within the 1K column address space
1	Reads cross row at 1K boundaries

9 Electrical Specifications:

9.1 Absolute Maximum Ratings

Table 20: Absolute Maximum Ratings

Parameter	Symbol	Rating	Unit	Notes
Voltage to any ball except V_{DD} , V_{DDQ} relative to V_{SS}	V_T	-0.4 to $V_{DD}/V_{DDQ}+0.4$	V	
Voltage on V_{DD} supply relative to V_{SS}	V_{DD}	-0.4 to +4	V	
Voltage on V_{DDQ} supply relative to V_{SS}	V_{DDQ}	-0.4 to +4	V	
Storage Temperature	T_{STG}	-55 to +150	°C	1

Notes 1: Storage temperature refers to the case surface temperature on the center/top side of the PSRAM.

Caution:

Exposing the device to stress above those listed in Absolute Maximum Ratings could cause permanent damage. The device is not meant to be operated under conditions outside the limits described in the operational section of this specification. Exposure to Absolute Maximum Rating conditions for extended periods may affect device reliability.

9.2 Pin Capacitance

Table 21: Bare Die Pin Capacitance

Parameter	Symbol	Min	Max	Unit	Notes
Input Pin Capacitance	C_{IN}		2	pF	$V_{IN}=0V$
Output Pin Capacitance	C_{OUT}		3	pF	$V_{OUT}=0V$

Note: spec'd at 25°C.

Table 22: Package Pin Capacitance

Parameter	Symbol	Min	Max	Unit	Notes
Input Pin Capacitance	C_{IN}		6	pF	$V_{IN}=0V$
Output Pin Capacitance	C_{OUT}		8	pF	$V_{OUT}=0V$

Note: spec'd at 25°C.

Table 23: Load Capacitance

Parameter	Symbol	Min	Max	Unit	Notes
Load Capacitance	C_L		15	pF	

Note: System C_L for the use of package

9.3 Decoupling Capacitor Requirement

It is required to have a decoupling capacitor on VDD pin for IO switchings and psram internal transient events. A low ESR 1 μ F ceramic cap is recommended. To minimize parasitic inductance, place the cap as close to VDD pin as possible. An optional 0.1 μ F can further improve high frequency transient response.

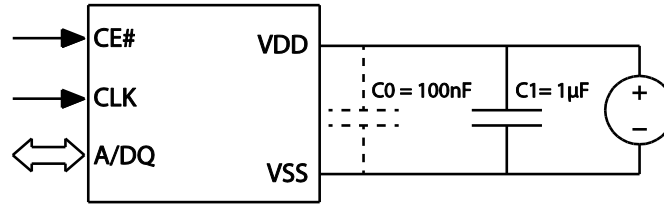

9.4 Operating Conditions

Table 24: Operating Characteristics

Parameter	Min	Max	Unit	Notes
Operating Temperature (extended)	-40	105	°C	
Operating Temperature (standard)	-40	85	°C	

9.5 DC Characteristics

Table 25: DC Characteristics

Symbol	Parameter	Min	Max	Unit	Notes
V _{DD}	Supply Voltage	2.7	3.6	V	
V _{DDQ}	I/O Supply Voltage	2.7	3.6	V	
V _{IH}	Input high voltage	V _{DDQ} -0.4	V _{DDQ} +0.2	V	
V _{IL}	Input low voltage	-0.2	0.4	V	
V _{OH}	Output high voltage (I _{OH} =-0.2mA)	0.8 V _{DDQ}		V	
V _{OL}	Output low voltage (I _{OL} =+0.2mA)		0.2 V _{DDQ}	V	
I _{LI}	Input leakage current		1	μA	
I _{LO}	Output leakage current		1	μA	
I _{CC}	Read/Write @ 13MHz		3	mA	2
	Read/Write @133MHz		14	mA	2
ISB _{EXT}	Standby current (105C)		350	μA	1,3
ISB _{STD}	Standby current (85C)		250	μA	3

- Note
- 1: Spec'd up to 105°C.
 - 2: Current is only characterized.
 - 3: Without CLK toggling. ISB will be higher if CLK is toggling.
 - 4: Slow Refresh.
 - 5: For typical current please refer table 26 & table 27.

9.6 ISB Partial Array Refresh Current

Table 26: Typical PASR Current @ 25°C

Standby Current @ 25°C			
PASR	ISB –typical mean	Unit	Notes
Full	100	μA	1,2
1/2	90	μA	1,2
1/4	85	μA	1,2
1/8	80	μA	1,2

Table 27: Typical PASR Current @ 85°C

Standby Current @ 85°C			
PASR	ISB –typical mean	Unit	Notes
Full	195	μA	2
1/2	169	μA	2
1/4	156	μA	2
1/8	150	μA	2

Note 1: Slow Refresh current is only attainable by enabling Slow Refresh Frequency (see Table 16)

Note 2: PASR Current is only characterized based on 64M density without CLK toggling.

9.7 AC Characteristics

Table 28: READ/WRITE Timing

Symbol	Parameter	-7 (133MHz)		-9 (109MHz)		Unit	Notes
		Min	Max	Min	Max		
tCLK	CLK period	7.5		9.2		ns	
tCH/tCL	Clock high/low width	0.45	0.55	0.45	0.55	tCLK	
tKHKL	CLK rise or fall time		1.0		1.2	ns	
tCPH	CE# HIGH between subsequent burst operations	18		18		ns	
tCEM	CE# low pulse width		8		8	μs	Standard temp
			3		3	μs	Extended temp
tCEM	CE# low pulse width	3		3		tCLK	Minimum 3 clocks
tCSP	CE# setup time to CLK rising edge	2.5		2.5		ns	
tCSP2	CE# rising edge to next CLK falling	1.5		1.5		ns	
tCHD	CE# hold time from CLK falling edge	2.5		2.5		ns	
tSP	Setup time to active CLK edge	1.1		1.1		ns	
tHD	Hold time from active CLK edge	1.1		1.1		ns	
tRBXwait	Row Boundary Crossing Wait Time	10	65	10	65	ns	
tHZ	Chip disable to DQ/DQS output high-Z		6		6	ns	
tRC	Write Cycle	60		60		ns	
tRC	Read Cycle	60		60		ns	
tPU	Device Initialization	150		150		μs	
tRP	RESET# low pulse width	1		1		μs	
tRST	Reset to CMD valid	2		2		μs	

Table 29: DDR timing parameters

<i>Symbol</i>	<i>Parameter</i>	<i>-7 (133MHz)</i>		<i>-9 (109MHz)</i>		<i>Unit</i>	<i>Notes</i>
		<i>Min</i>	<i>Max</i>	<i>Min</i>	<i>Max</i>		
tCQLZ	Clock rising edge to DQS low	1	6	1	6	ns	
tDQSCK	DQS output access time from CLK	2	5.5	2	5.5	ns	
tDQSQ	DQS – DQ skew		0.6		0.6	ns	
tDS	DQ and DM input setup time	1.1		1.1		ns	
tDH	DQ and DM input hold time	1.1		1.1		ns	

10 Change Log

Version	Who	Date	Description
1.0		Aug 24, 2017	Initial Version
1.5		Oct 31, 2017	Removed Hybrid 64, modified Write 4 bytes & absolute voltage, VIL/VIH
1.6		Nov 13, 2017	Modified spec of ISB, PASR, ICC
1.7		Dec 21, 2017	Revised RLC, WLC tables
1.8		Jan 01, 2018	Revised Fmax of bare die to 200MHz
1.9		Jun 13, 2018	Added part APS6408L-3OBM
2.0		Nov 26, 2018	Updated some latency wording; added operation latency table
2.1		Jan 17, 2019	Updated temperature; ordering information; unified part number to OBM for RBX read & special parts of STM32L4+ family
3.1a		Aug 23 2019	Updated section 2, 4, 8.5, 9.7, Table 23 and Table 25 from OBM v3.1a, Updated section 6 from OBM BA v2.0; Updated section 6 from OC v1.7; Updated Table 5, Table 13, Table 15
3.2		Sep 28, 2019	Updated header and page 1; updated Table 26 and Table 27
3.3		Oct 24, 2019	Updated defaults setting in Table 7
3.4		Nov 07, 2019	Updated notes for Table 3, Table 14, Table 18, Table 25, section 8.5 and section 9.3
3.5		Nov 14, 2019	Updated notes in section 8.5, Table 15, Table 17 and Table 28
3.5a		Nov 20, 2019	Update typo in section 8.7, 9.3 and 9.6
3.5b		Dec 13, 2019	Revised the typo in section 8.7
3.6		Oct 18, 2021	tCEM revised data by BD suggest (E3_OPI_64Mb/128Mb) Standard temp: 4 us -> 8 us. Extended temp: 1 us -> 3 us.
3.6a		Dec 07, 2021	Revised some figure can't display grid (ex: Don't care/Undefined) when conversion to PDF.
3.7		Dec 29,	Added part number APS6408L-3OBM and APS6408L-3OBMX.

		2021	
3.8	Kim/ Eric/ Wayne	Aug 15, 2022	Revised typos
3.9	Kim	Mar 31, 2023	Add the description "CE# should be kept low until the last byte of data has been received by the host." On read operation. Add tCSP2 on write waveform
4.0	Kim	Jun 27, 2023	Remove tQH on DQS & DQ timing waveform Adjust the description about interface.